

RHEEM 2 STAGE COMPRESSOR WIRING DIAGRAM

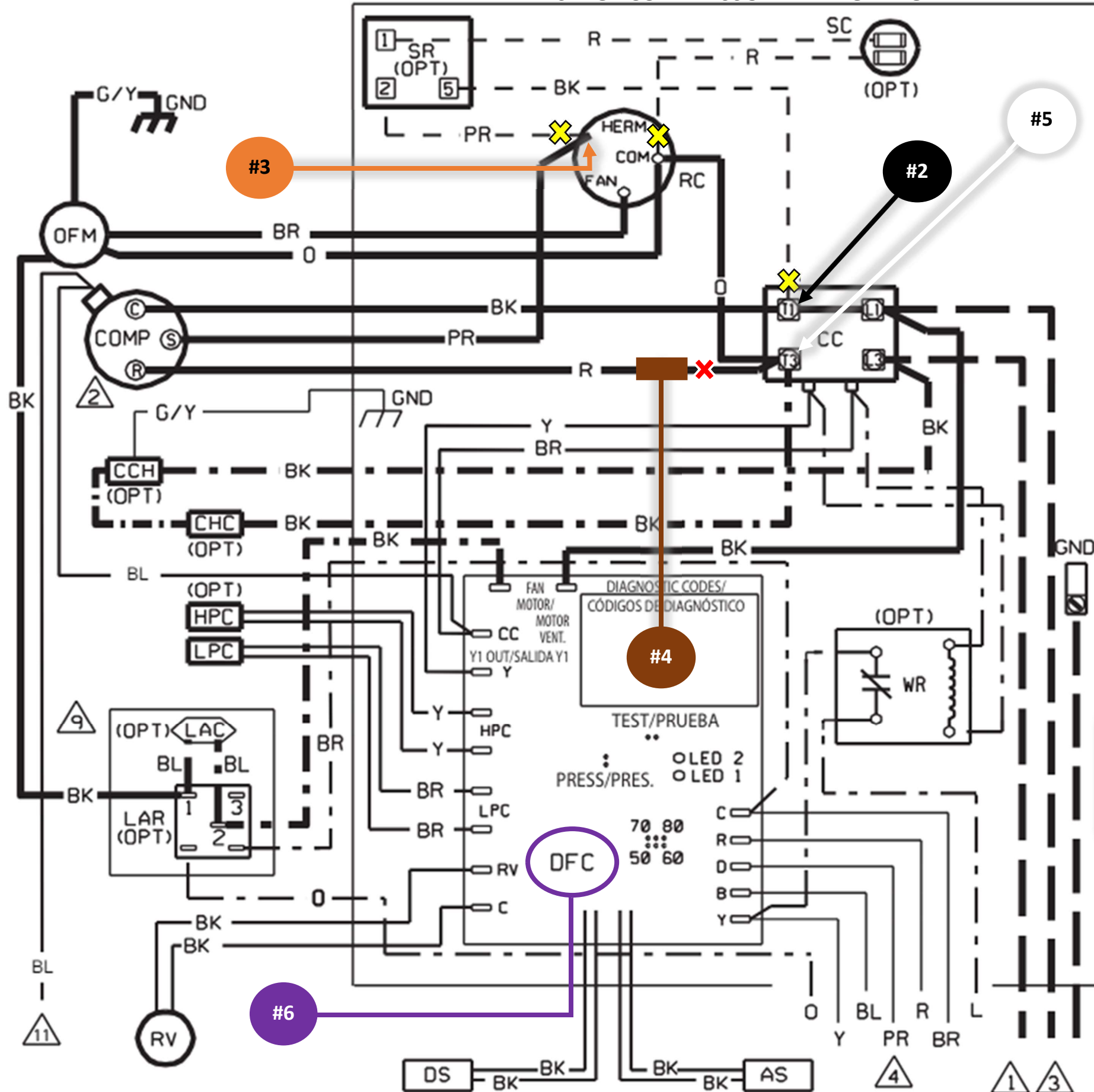

1. Before Easy Start installation!
All connectors used must be 600VAC rated!
 If present in your system all start component connections and wires need to be removed where you see a yellow X

2. Put Easy Start Black with compressor common (BK) on the contactor behind the screwhead using a fork or ring terminal connector.

3. Put Easy Start Orange on the run-capacitor Herm (H) position.

4. Remove compressor run (R) from the contactor [see red X] and Splice to Easy Start Brown.
NOTE:
The wire between the contactor and the run-capacitor common remains untouched, unused and nothing connected at either end!

5. Where you removed the last connection Put Easy Start White on the contactor behind the screwhead using a fork or ring terminal connector.

6. See DFC circled in purple this is a defrost board. This is NOT a compressor monitoring board. NO Easy Start settings are adjusted.